

EJOT ALtracs® Xt

vs. ALtracs® Plus



Thread forming in light alloy

Each screw joint is only as strong as its weakest link. When using a steel screw in light alloy, the light alloy part is usually said weak link.

The EJOT ALtracs® product family comes with a thread that is specialized for the use in light alloy. With a (compared to machine screws) reduced screw flank angle of 33° the thread flank of the female thread is significantly enlarged. Thus each female thread has a higher load-bearing capacity than usual. This feature – coupled with the circular cross-section of the thread – enables high strength screw joints at low installation depths (i.e. 1.5 x screw diameter).



New benchmarks with ALtracs® Xt

The ALtracs® Xt is the advancement of the well-proven ALtracs® Plus. The ALtracs® Xt creates new benchmarks when it comes to process reliability of thread forming assemblies. This is especially beneficial, since it leads to higher allowable tolerances, draft angles as well as more design possibilities regarding installation depths.

Your additional advantages with ALtracs® Xt:

Improved reliability for the assembly process

Due to the consequent use of naturally inspired design principles the thread geometry is further optimized. Unnecessary friction surfaces were identified and removed. An additional feature is the *Progressive Forming Profile* at the tip of the screw. This special forming zone further reduces friction during the thread forming process. Together, both features lead to a significantly smoother torque curve during the assembly.

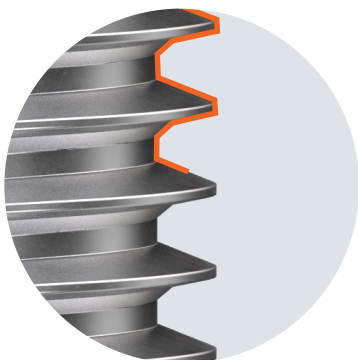

ALtracs® Plus

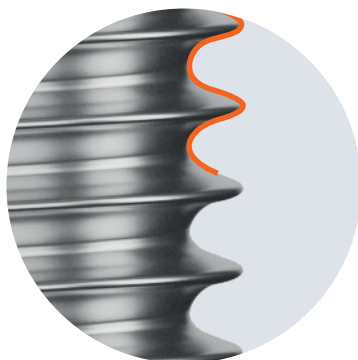

ALtracs® Xt

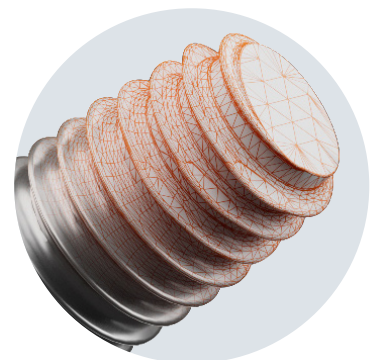

Progressive Forming Profile at the tip of the ALtracs® Xt

Use of naturally inspired design principles for the flank geometry of ALtracs® Xt

Bringing it together.

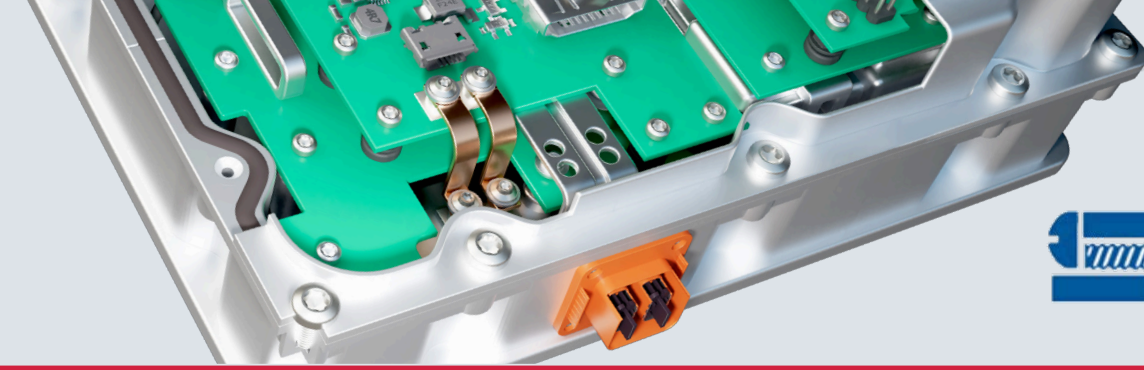

Thanks to the optimized thread geometry of ALtracs® Xt a drive torque reduction of up to 50% is possible. With the circular cross-section of the load-bearing thread the failure torques stay on the same high level as with ALtracs® Plus.

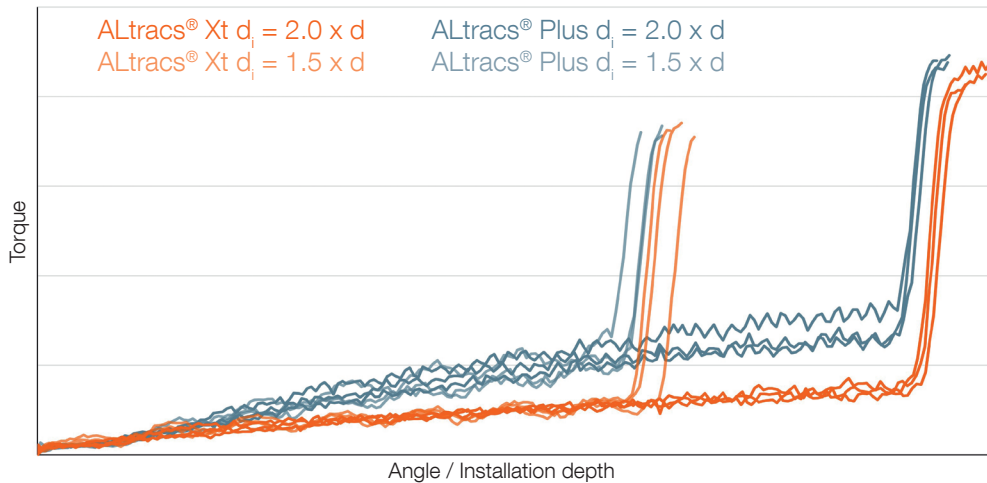

Torque curve for different installation depths (d_i) ALtracs® Xt vs. ALtracs® Plus

Improved castability for your components

Thanks to the significantly improved process capability of ALtracs® Xt the requirements for the accuracy of (cast) components is reduced. Even with bigger tolerances regarding hole diameter / draft angle there will still be very solid process windows with ALtracs® Xt (i.e. with draft angles of up to 2°). Coupled with the outstanding performance at low installation depths this leads to better wear behavior in the die cast tools. Thus the use of ALtracs® Xt in cast holes (without further machining) enables even more cost-saving potential.

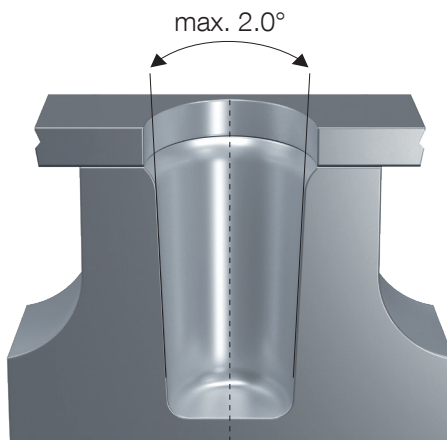

d_i [mm]	Pre-hole tolerances [mm]
2.5 - 3.5	±0.05
4.0	±0.06
5.0	±0.07
6.0 - 7.0	±0.10
8.0 - 10.0	±0.14

For further information, especially regarding bigger tolerances, please contact **Semblex**.

Further information at: <https://www.semblex.com>
 Phone: 630-833-2880, email: sales@semblex.com
 Semblex® Corporation, 900 North Church Road, Elmhurst, Illinois 60126

Bringing it together.