

REMFORM® II™ "HS" SCREWS FOR PLASTICS

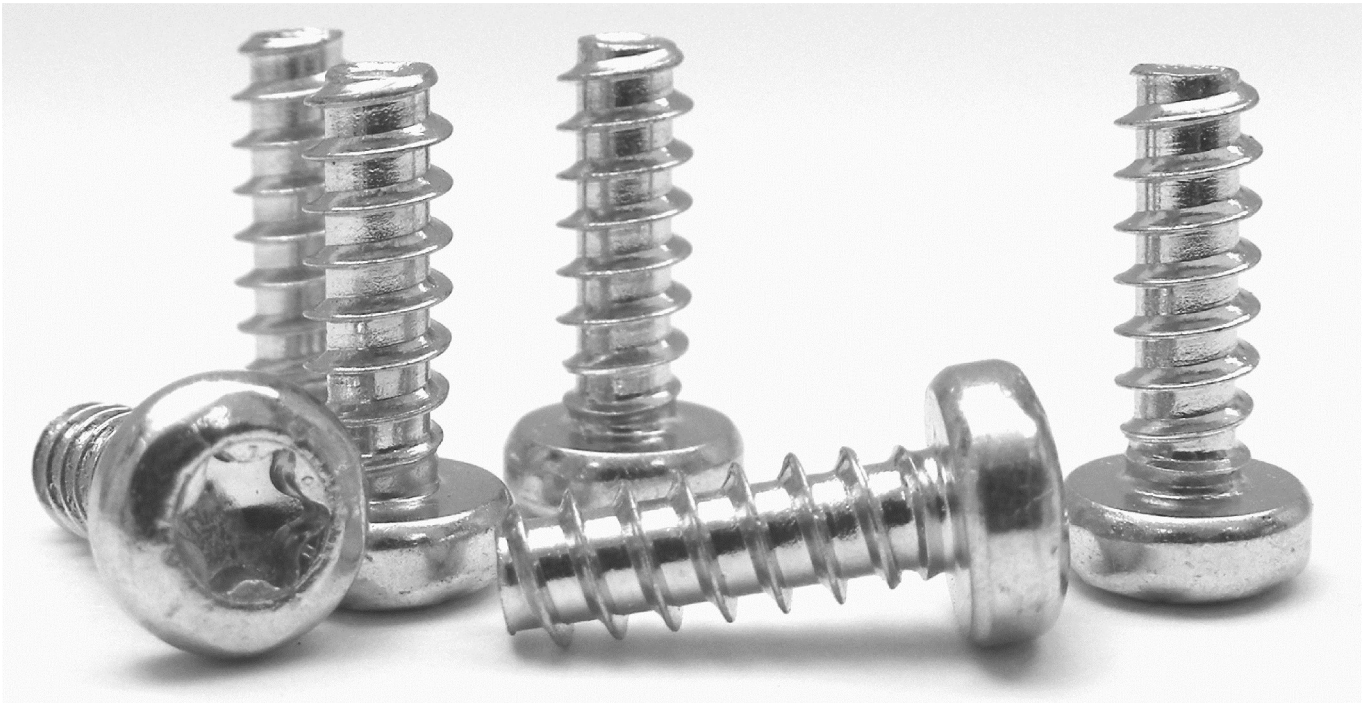

REMFORM® II™ "HS" Screws

REMFORM® II™ "HS" fasteners were developed to combine the features of REMFORM® II™ and REMFORM® II™ "F" fasteners with an optimized gap between the threads and core diameter.

The optimized pitch distance in combination with an optimized core diameter allows a better flow of the mating plastic material downwards toward the load flank and will accept a higher amount of material between the flanks. This reduces the risk of overstressing and cracking of the plastic material particularly during the assembly process. The optimized core diameter provides a higher torsional strength and is an advantage when the fastener is used in higher strength or fiber reinforced materials. In applications that require a higher axial thread engagement, the optimized pitch allows more threads to be in contact with the plastic material.

In addition to specific dimensional parameters the REMFORM® II™ "HS" fastener comprises the Unique Radius Flank™ asymmetrical thread design which is the standard for all REMFORM® fasteners. The asymmetrical thread minimizes radial hoop stress and reduces the risk of boss bursting. In addition the narrow and radius shaped tip angle decreases the stress in the mating material.

Leaders in Lowering the Cost of Assembly

REMFORM® II™ "HS" SCREWS FOR PLASTICS

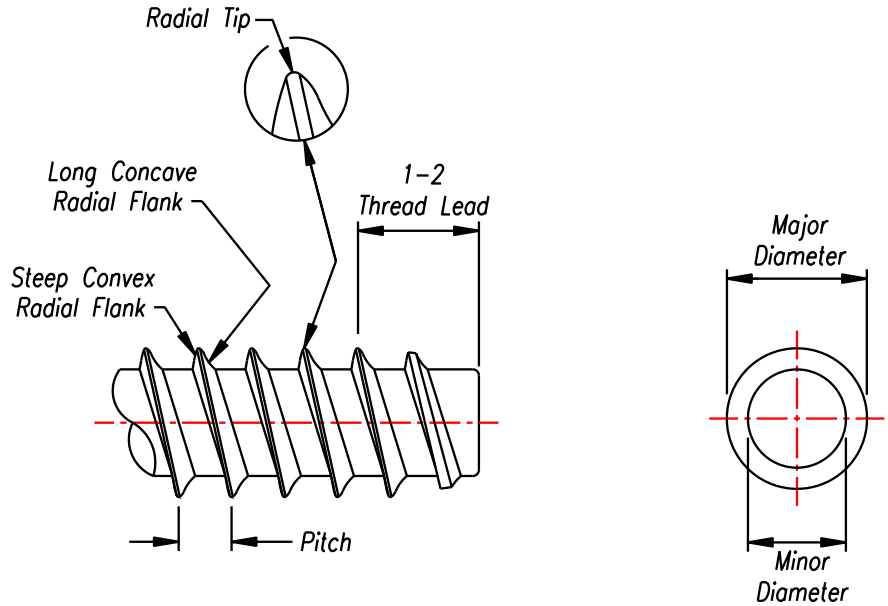

Metric Series

| SIZE | PITCH | MAJOR DIA. | | MINOR DIA. |
|------|-------|------------|-------|------------|
| | | Max. | Min. | Min. |
| 2.0 | 0.78 | 2.08 | 2.00 | 1.28 |
| 2.2 | 0.85 | 2.28 | 2.20 | 1.43 |
| 2.5 | 0.95 | 2.60 | 2.50 | 1.64 |
| 3.0 | 1.12 | 3.10 | 3.00 | 2.01 |
| 3.5 | 1.29 | 3.60 | 3.50 | 2.37 |
| 4.0 | 1.46 | 4.10 | 4.00 | 2.73 |
| 4.5 | 1.63 | 4.60 | 4.50 | 3.09 |
| 5.0 | 1.80 | 5.15 | 5.00 | 3.43 |
| 6.0 | 2.14 | 6.15 | 6.00 | 4.16 |
| 7.0 | 2.48 | 7.18 | 7.00 | 4.86 |
| 8.0 | 2.82 | 8.18 | 8.00 | 5.58 |
| 9.0 | 3.16 | 9.25 | 9.00 | 6.28 |
| 10.0 | 3.50 | 10.25 | 10.00 | 7.00 |

Dimensions in mm

Note: Sizes 1.0 - 1.8 available upon request

Shown are typical applications suitable
for REMFORM® II™ "HS" screws

REMFORM® II™ "HS" SCREWS FOR PLASTICS

RECOMMENDED HOLE SIZES

| MATERIAL TYPE | H HOLE DIA. Factor X Min. Screw Dia. |
|--------------------|---|
| PP | 0.75 |
| PE | 0.75 |
| PA (Nylon 6 / 6.6) | 0.75 |
| ABS / PC Blend | 0.75 |
| ASA | 0.75 |
| ABS | 0.75 |
| PVC (rigid) | 0.80 |
| SAN | 0.80 |
| PS | 0.80 |
| PBT | 0.80 |
| PET | 0.80 |
| PC | 0.80 |
| PPO | 0.80 |
| PET 30% GF | 0.80 |
| PC 30% GF | 0.82 |
| PPO 30% GF | 0.82 |
| PA 6 30%GF | 0.85 |
| PBT 30% GF | 0.85 |

SUGGESTED BOSS CONFIGURATION

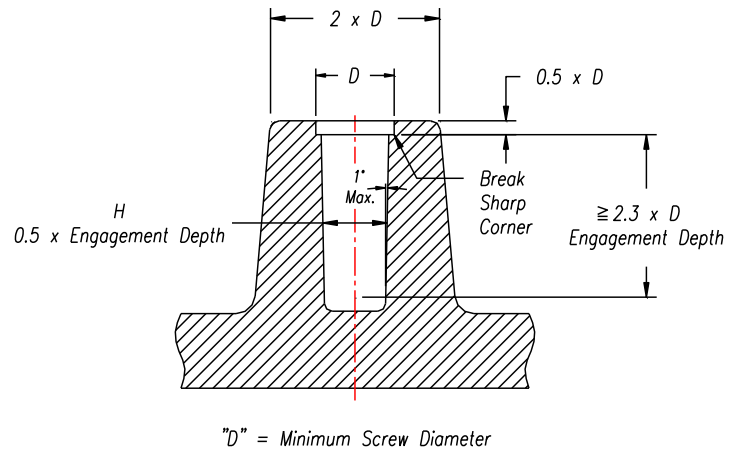

Hole sizes for the plastics listed in the table are derived by multiplying the minimum screw diameter by the factor listed in the table. The resulting hole size should be considered as a starting point which may need to be adjusted due to specific application conditions.

Reduced Hoop Stress

The radial tip thread crest of REMFORM® II™ "HS" screws reduces sharp corners, which reduces radial hoop stress in the plastic caused by thread forming.

When a threaded fastener is tightened, nearly all of the axial tightening load, designated **F**, is opposed by the trailing or pressure flank of the screw and the mating thread flank of the internal thread. The steep pressure flank transfers most of the resultant tightening load in the axial direction, **F_a**, minimizing boss bursting tendencies created by the radial force, **F_r**. The axial force, **F_a**, is over 4.5 times greater than **F_r**, the radial force.

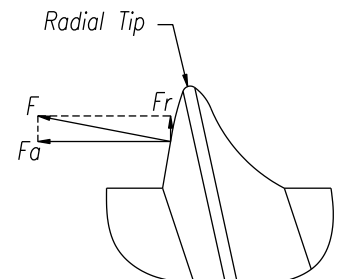

The Unique Radius Flank™ Thread Form

REMFORM® II™ "HS" screws employ the Unique Radius Flank™ asymmetrical thread form shown in the drawing to the right. The leading thread flank is most influential in forming the mating thread. The intercepting radius form on the leading flank is there to promote efficient material displacement and material flow. The pressure flank which opposes the fastener head is engineered to resist pull-out forces, whether they be applied by a tensile load or induced by torque. The steep pressure flank has a subtle radius designed to increase resistance to pullout and to efficiently develop tension. It also provides excellent material contact resulting in a high resistance to the internal threads stripping. In applications where the failure mode is fastener fracture, the high torsional strength of REMFORM® II™ "HS" fasteners ensures a high failure torque. This unique thread and its narrow tip angle efficiently displace material and therefore require minimal energy to form an internal thread. The tip also utilizes a radius to better create the internal thread without increasing hoop stress in the plastic.

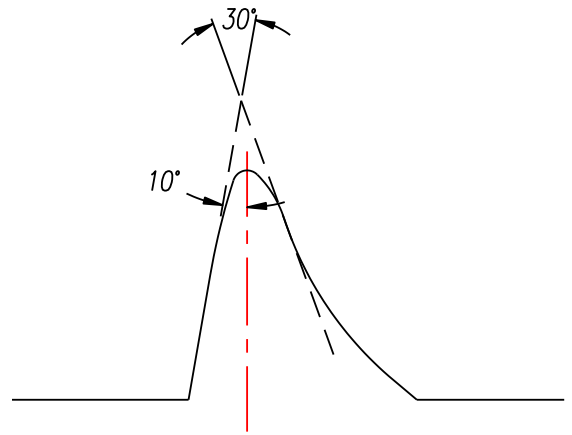

The REMFORM® II™ "HS" unique asymmetrical radius flank thread form has the thread forming advantages of a 30° thread, without the difficulty of manufacturing a 30° thread.

DISCLAIMER CLAUSE

The values shown in this brochure are for guidance only. Their use and reliance thereon for any purpose by anyone is entirely voluntary and at the sole risk of the user. REMINC/REMINC are not responsible for any loss, claim or damage resulting from their use. Consult our application engineers or the application engineering department of one of our many qualified producers for your specific application data.

TECHNICAL ASSISTANCE

This brochure contains basic information needed to achieve the cost-savings potential of REMFORM® II™ "HS" fasteners.

To obtain further assistance and a list of qualified producers, visit our website at www.remform.com or contact REMINC or CONTI.

SPECIFY GENUINE PRODUCTS

Make sure you're getting genuine REMINC/CONTI design, engineering, quality, reliability and performance. Only genuine REMINC/CONTI products meet the rigorous standards created by REMINC/CONTI.

Patents and trademarks issued and/or pending worldwide.



900 North Church Road, Elmhurst, IL 60126

800-323-1736 | 630-833-2880

www.semblex.com

